



LITHIUM IRON PHOSPHATE BATTERY

FEATURES Lithium Iron Phosphate (LiFePO4): the Safest Lithium Technology.
 Integrated Battery Management System(BMS).
 Bluetooth/RS485/RS232/SMBus/CANBus (Optional).
 SOC LED/LCD Indicator(Optional).

PERFORMANCE Long Cycle Life > 2000cycles @ 100% DOD.
 High Density, High Discharge Current, High Temperature Range.
 Low Weight, Free Maintenance.
 Fast Charging.
 Environment Friendly.



MIL12-1,28(12.8V100Ah, 1280Wh)

BATTERY DATA SHEET

Electrical Parameters

Nominal Voltage	12.8V
Rated Capacity	100Ah
Energy	1280Wh
Resistance	≤30m Ω
Efficiency	99%
Cycle Life	>2000cycles @1C,100% DOD
Self Discharge	2% per Month
Max. Modules in Series/Parallel	4S2P

Mechanical Parameters

Dimension(L x W x H)	330 x 173 x 212 mm 13 x 6.8 x 8.3"
Weight	11.6kg(25.57lbs)
Terminal Type	M8
Battery Housing	ABS, UL-94 V-0
Housing Protection	IP65
Cell Type-Chemistry	LiFePO4
SOC Display(Optional)	LED/LCD Indicator

Discharge Parameters

Continuous Discharge Current	100A
Pulse Discharge Current	150A (>3 seconds)
Recommended Volt. Disconnect	10V
BMS Discharge Cut-off Voltage	8V
Reconnect Voltage	9.2V
Short Circuit Protection	200~600 us

Charge Parameters

Charge Method	CC-CV
Charge Voltage	14.4~14.8V
Recommended Float Voltage	13.8V
Recommended Charge Current	50A
Maximum Charge Current	100A
BMS Charge Cut-off Voltage	15.6V

Compliance Certificate

Certifications	UL2054(MH63377)
	CE
	IEC62133 & CB
	KC
	BIS
Shipping Classification	UN3480, Class 9,UN38.3

Temperature Parameters

Discharge Temperature	-30 to 60°C (-22 to 140°F)
Charge Temperature	0 to 45°C (32 to 113°F)
Storage Temperature	-40 to 60°C(-40 to 140°F)
BMS High Temperature Cut-off	80°C(176°F)



Performance Characteristics

CYCLE LIFE vs. DEPTH OF DISCHARGE(DOD)
DISCHARGE @ 1C, 25 °C

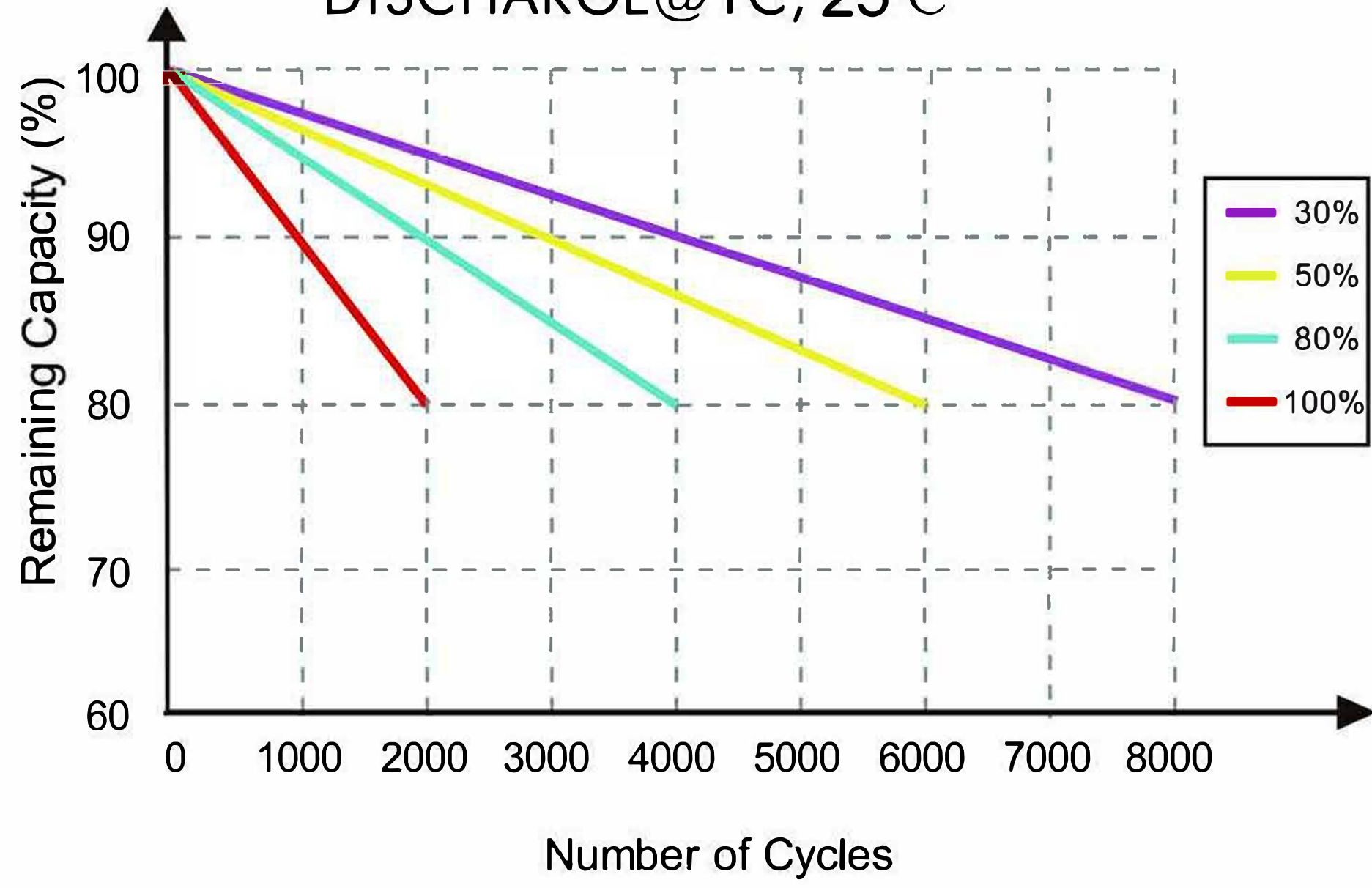

DISCHARGE CAPACITY at VARIOUS TEMPERATURES
DISCHARGE @ 1C, 25 °C

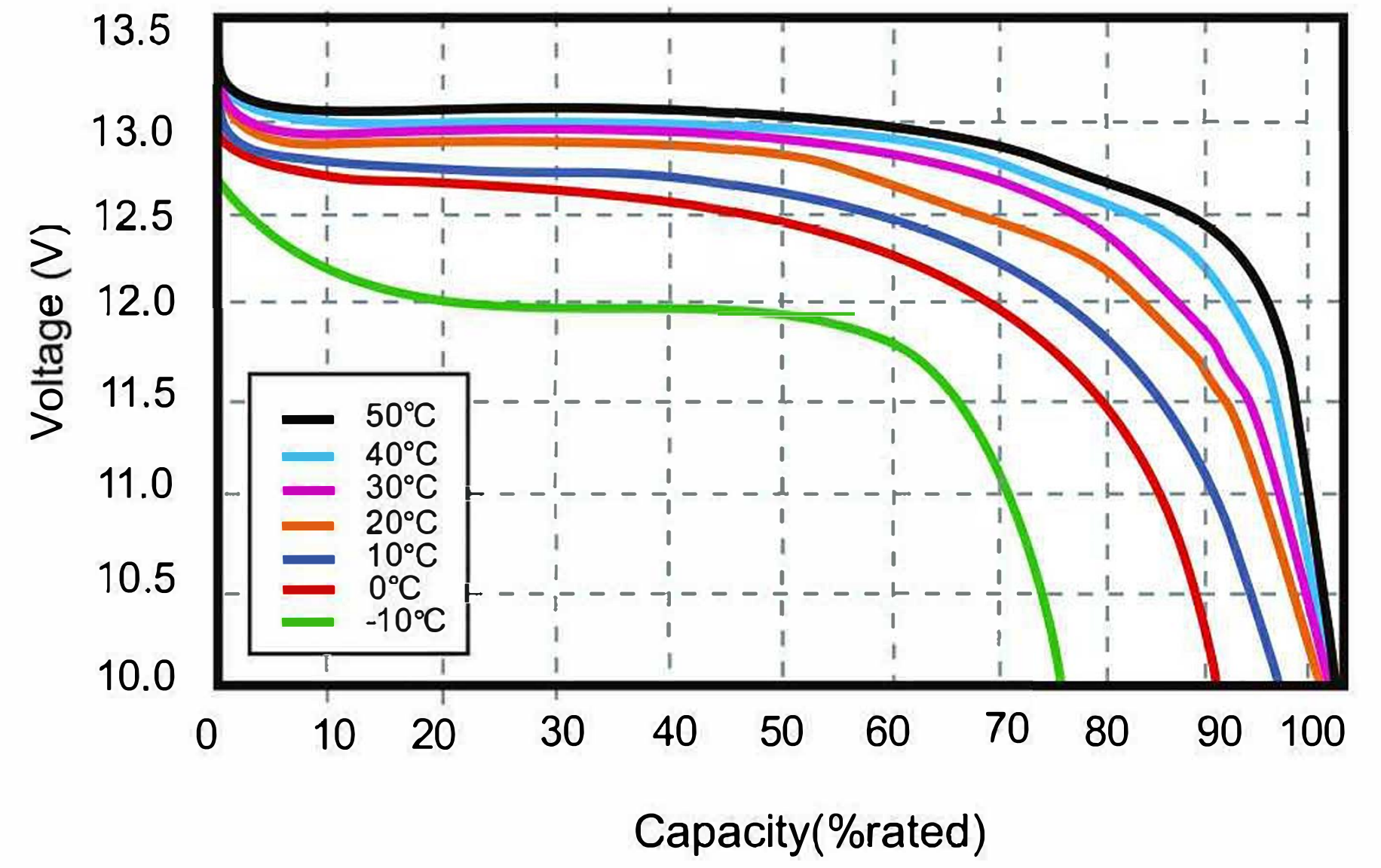

STATE OF CHARGE CURVE @ 1C, 25 °C

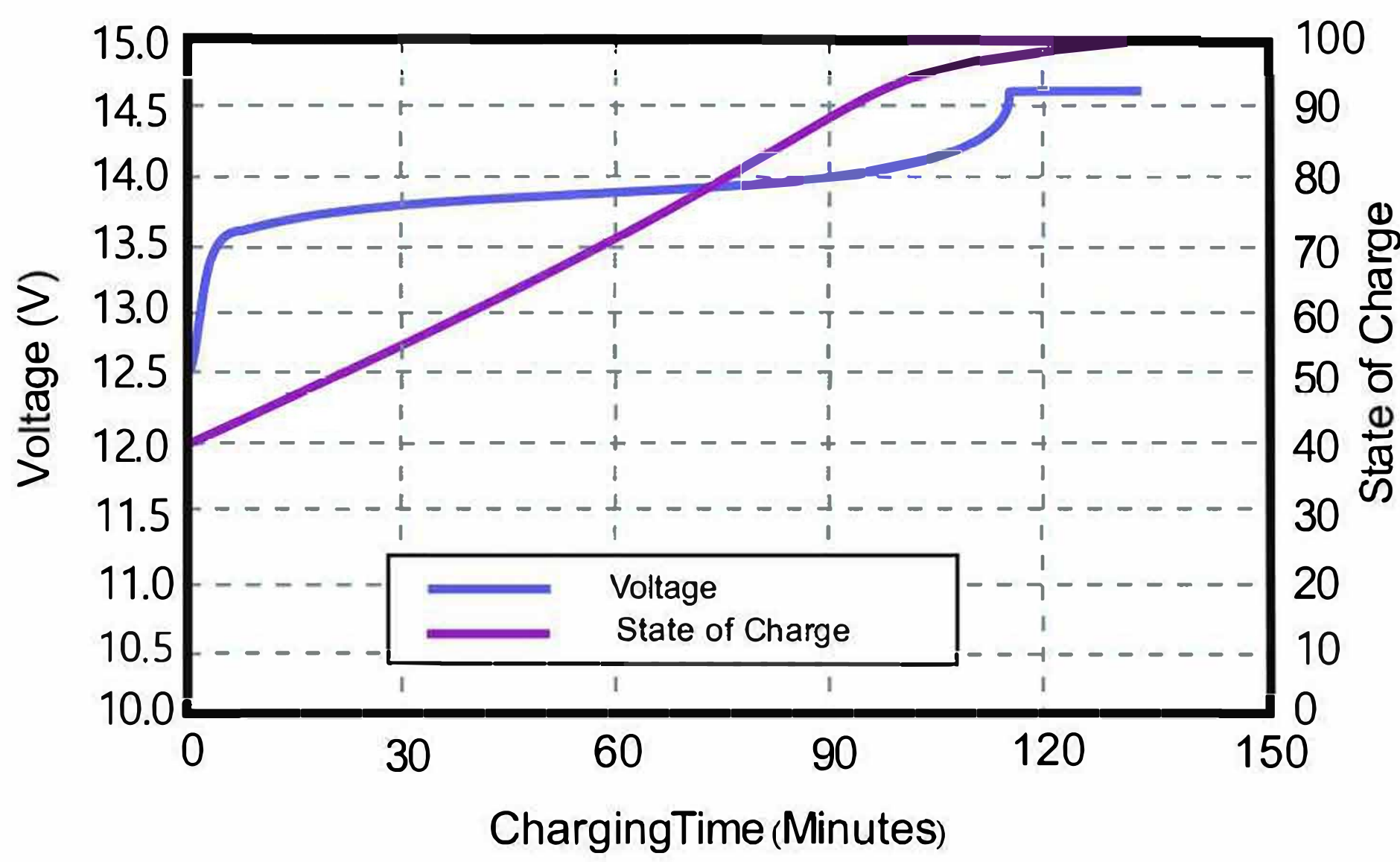

CHARGING CHARACTERISTICS @ 1C, 25 °C

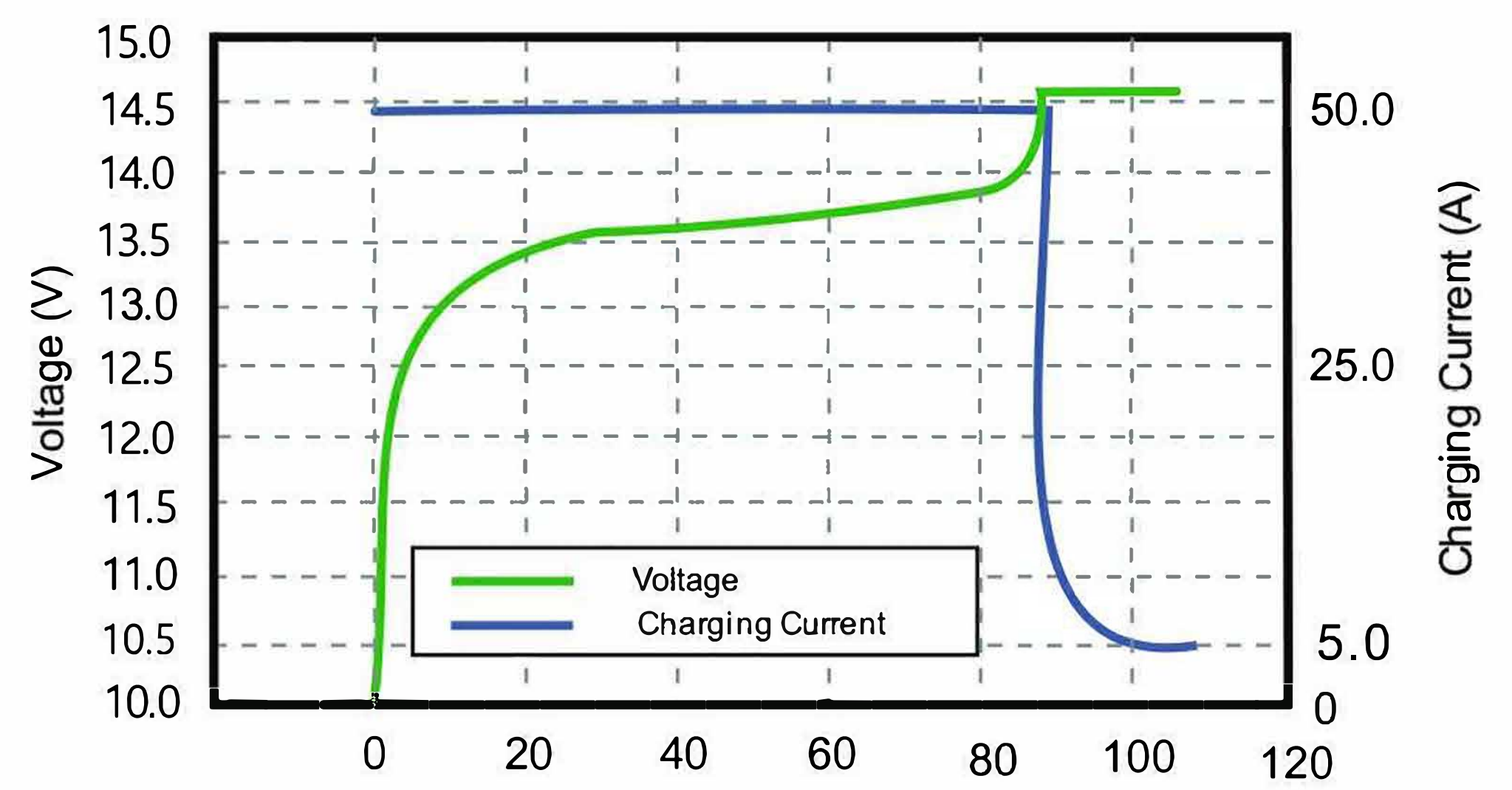

Battery Dimension

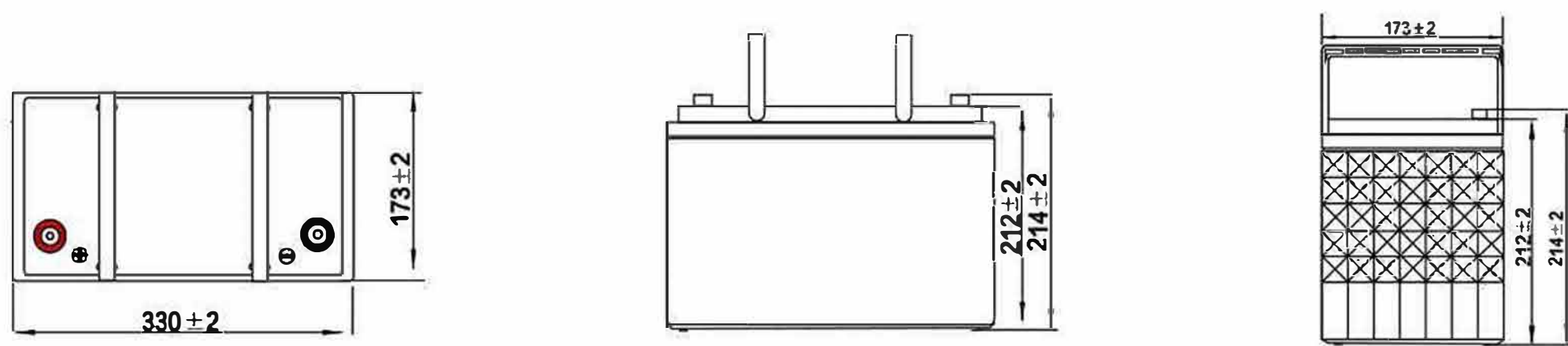

M8 - 1.0x 8mm
Threaded Hole

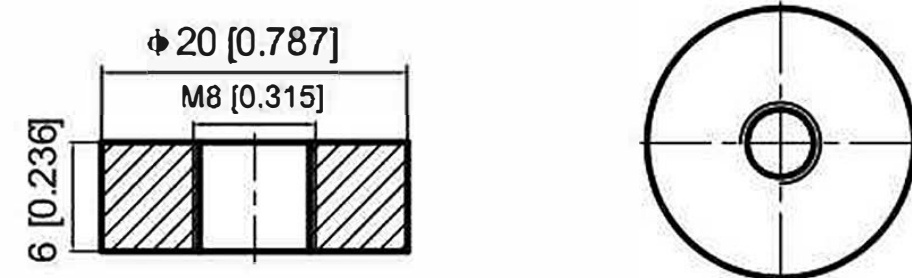

Battery Applications

- + Data Center UPS
- + Telecom Backup Power
- + Military Power Supply
- + Solar Energy Storage System
- + Solar Street LED Lightings
- + Autonomously Guided Vehicles (AGVs)
- + Industrial Robotics & Handling Equipment
- + Aerial Work Platform
- + Floor Cleaning Machines
- + Power Tools, Lawn Mower
- + Electric Bike & Motorcycles
- + Electric Mobilities(E-scooters, Wheelchair)
- + Golf Trolley & Golf Carts
- + Medical Devices
- + Electric Ships
- + Passenger Vehicles

Battery Recycle



NOTE: Do Not Mix With Sealed Lead Acid Batteries When Recycling.

See User's Manual for Proper Operation.

BLACKBULL BATTERY SYSTEMS